



9" Modero® ViewPoint® Touch Panel with Intercom

MVP-9000i-GB, Black (FG5967-01)

MVP-9000i-GW, White (FG5967-02)



Overview

The MVP-9000i redefines touch panel control offering both wireless and wired functionality, new user interface capabilities like gestures and page transitions, a stunning 9" widescreen 24-bit color display, full digital duplex telephone or intercom interface and built-in 802.11a/b/g Wi-Fi card with antenna diversity. The MVP-9000i switches seamlessly to wireless mode when removed from the PoE docking station. Transfer touch panel pages, upgrade the firmware or display photo files using the USB or mini-SD card slot. Available in white or black, the MVP-9000i also features a capacitive navigation pad, 4 programmable buttons, over 1 GB of useable flash memory and supports 5 hours of continuous use and three days of standby time. The Modero MVP-9000i is certified compatible with Cisco® Compatible Extensions (CCS), Version 4.

Common Applications

The MVP-900i is ideal for a wide variety of residential and commercial control and automation applications where flexibility of docked or mobile 802.11a/b/g functionality and extended battery life is desired. This is an ideal solution for extremely noisy wireless environments like MDUs and applications that require telephone/intercom functionality.

Features

- Automatically switches between Ethernet connectivity when docked and Wi-Fi when out of dock
- New user interface capabilities including gesturing and 7 different page transitions
- International Fonts Support – The MVP-9000i provides support for right to left languages such as Arabic, a combination of language styles (right to left, and left to right) can also be used allowing inclusion of Arabic and English on the same screen
- 802.11a/b/g Wi-Fi with antenna diversity for improved wireless reliability and features enhanced wireless security protocol
- Extended battery life - five hours of continuous use and three days of standby time
- Micro-SD and USB stick support for easy file transfers and photo uploads
- VoIP intercom and SIP telephone (requires AMX Gateway) ready
- 9.0" color active - matrix TFT with 16x9 aspect ratio
- Screen Resolution – 800x480
- Display Colors – 24-bit color depth
- Brightness – 400 nits
- LED backlit display
- Supports full motion JPEG providing at least 24 frames per second
- IPS Technology enables wide viewing angles - 85 degrees in all directions
- Contrast Ratio – 900:1
- Built-in speaker and microphone
- 256 MB mobile DDR SDRAM/2GB SD Flash with 1.1GB of useable space
- USB port and mini-SD card slot for file transfer and photo uploads
- Capacitive navigation pad with up/down/right/left/select
- 4 user-programmable capacitive buttons with on-screen fly out labels
- Supports landscape or portrait mode
- Integrated kickstand and stylus
- Available in black or white
- Versatile placement options including table and wall charging stations or integrated kickstand
- Works with AMXmeetingroom, VisualArchitect and AMXhome
- Cisco compatible with CCX, Version 4

Specifications

TOUCH SCREEN DISPLAY	
Panel Type	TFT Color Active-Matrix
Active Screen Area (WH)	7 3/4" x 4 1/2" (19.7 cm x 11.8 cm), 9" (diagonal)
Resolution (WH)	800 x 480 pixels (HV) @ 60 Hz refresh rate
Aspect Ratio (WH)	16:9
Brightness	400 cd/m2
Channel Transparency	8-bit Alpha blending
Contrast Ratio	900:1 max
Display Colors	16.7M colors (24-bit color depth)
Dot/pixel pitch	0.246 mm
Viewing Angle (Up/Down/Left/Right)	85/85/85/85

COMMUNICATIONS	
IR	Transmit only including AMX 38KHz, AMX 455KHz, and

	3rd party IR
AUDIO	
Mono Speaker	4 Ohm, 2 Watts 300Hz cutoff frequency
ENVIRONMENTAL	
Temperature (Operating)	0° C (32° F) to 40° C (104° F)
Battery Charging Temperature	0° C (32° F) to 30° C (86° F)
Operating & Battery Charging Humidity	20% to 85% RH
Temperature (Storage)	-20° C (-4° F) to 60° C (140° F)
Humidity (Storage)	5% to 85% RH
GENERAL	
Dimensions (HWD)	7 5/8" x 11" x 1 1/16" (19.4 cm x 27.9 cm x 2.7 cm)
Weight	3.60 lbs (1.63 kg)
Power Requirements (Without Charging)	<p>Panel with battery fully charged or with no battery:</p> <ul style="list-style-type: none"> •Constant current draw: 1.1 A @ 12 VDC •Startup current draw: 1.2 A @ 12 VDC •Auto Dim current draw: 0.6 A @ 12 VDC •Sleep current draw: 0.4 A @ 12 VDC •Standby current draw: 0.07 A @ 12 VDC •If panel is mounted onto a TDS or WDS, add 0.1 A to the above figures
Power Requirements (While Charging)	<p>Constant current draw: 2.0 A @ 12 VDC</p> <ul style="list-style-type: none"> •Auto Dim current draw: 0.5 A @ 12 VDC •Sleep current draw: 0.3 A @ 12 VDC •Standby current draw: NA •If panel is mounted onto a TDS or WDS, add 0.1 A to the above figures
Minimum Power Supply Required	<ul style="list-style-type: none"> •PS3.0 Power Supply (FG423-30) •PS-POE-AT High Power PoE Injector (FG423-81) through the Table Docking Station and Wall Docking Station (included with docking stations)
Power Modes	<ul style="list-style-type: none"> •ON: All necessary modules are powered up and device remains online with the NetLinX Master •ASLEEP: Only the backlight will be turned off after the user selectable time of inactivity has elapsed. Panel resumes the ON mode in ~ 1 second •STANDBY: Power to all components other than the touch screen is turned off after the user selectable time of inactivity has elapsed. Device will turn back on by touching the screen •SHUTDOWN: Power to all peripherals and components is turned off. The system remains in this

	mode until it is rebooted
Battery Duration	Five hours of continuous use Three days standby time
Memory	2GB internal microSD (1.1GB accessible to user)
Certifications	FCC Class B CE IEC/EN-60950 RoHS/WEEE Compliant WLAN: Cisco Compatible Extensions (CCX)
Included Accessories	PS 3.0 Power Supply (FG423-30) Stylus (pre-installed onto the left side of the unit)



Shown with
kickstand deployed



MVP-9000i
(Bottom View)

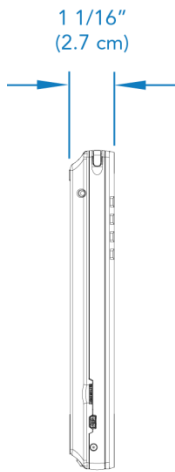

MVP-9000i
(Left View)

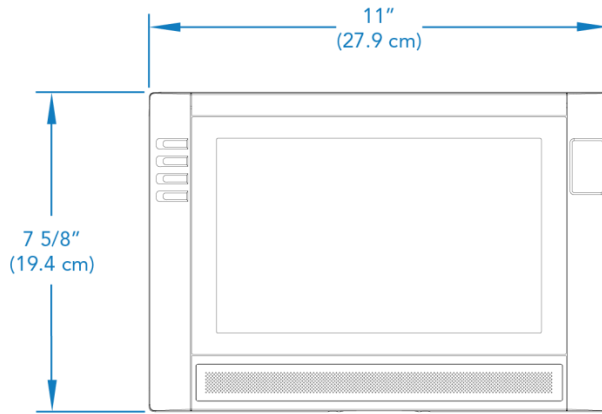

MVP-9000i
(Front View)



MVP-9000i
(Right View)

About AMX

AMX hardware and software solutions simplify the implementation, maintenance, and use of technology to create effective environments. With the increasing number of technologies and operating platforms at work and home, AMX solves the complexity of managing this technology with reliable, consistent and scalable systems. Our award-winning products span control and automation, system-wide switching and audio/video signal distribution, digital signage and technology management. They are implemented worldwide in conference rooms, homes, classrooms, network operation / command centers, hotels, entertainment venues, broadcast facilities, and more. ©2012 AMX. All rights reserved.

Specifications subject to change. Revised 2-April-2013.

AMX.com | 800.222.0193 | 469.624.8000 | +1.469.624.7400 | fax 469.624.7153