

UC-CX100-T

Crestron Flex Advanced Video Conference System Integrator Kit for Microsoft Teams® Rooms



- *Confferencing integration solution for Microsoft Teams® Rooms software*
- *Present, call, conference, and collaborate using your own device's UC conference platform (BYOD) or the native Microsoft Teams® Rooms platform*
- *Native Microsoft Teams® Rooms touch screen UI provides a consistent, simple user experience with one-touch meeting joins*
- *Complete kit contains a 10.1 in. tabletop touch screen, a UC presentation transmitter, and UC bracket assembly*
- *Optional integration with Crestron® control systems*
- *Direct connection option between UC Engine and tabletop touch screen for simple installation and configuration*
- *Network management and provisioning, system alerts, and tabletop touch screen pairing to the system's UC Engine through the XiO Cloud® service*
- *Premium-level support with Crestron Flex Care (optional)*
- *Enterprise-grade security - connects and communicates securely over any enterprise or SMB network*
- *Supports single or dual video displays (not included)*

The UC-CX100-T Crestron Flex integrator kit provides a customizable video conference solution for use with Microsoft Teams® Rooms software. It supports single or dual video displays¹ (not included) and features a UC presentation

transmitter, a tabletop touch screen and a UC bracket assembly.

Native Microsoft Teams® Rooms Experience

The UC-CX100-T system brings the full Microsoft Teams Rooms UC experience to any meeting space in an enterprise or SMB facility.

Custom Room Integration

The UC-CX100-T system provides the essential components needed to design a fully custom video conferencing space using your choice of display devices, cameras, speakers, microphones, and other AV equipment. Any Microsoft Teams software compliant USB camera and USB audio conferencing interface (or speakerphone) may be used.

Intuitive User Interface

With a large 10.1 in. (257 mm) capacitive touch screen display, the Crestron® tabletop touch screen ([TS-1070](#)) provides superior conferencing control in meeting rooms, huddle spaces, and executive offices. The touch screen also offers optional control of room lighting, shades, thermostats, and other equipment.²

Simplified Deployment

The UC Bracket Assembly provides preassembled components on one ready-to-mount bracket to simplify installation. The assembly can be mounted on a wall, or it can be attached to the rear of the display device. Crestron's direct connection method further simplifies installation with a single connection from the tabletop touch screen to the UC Bracket Assembly.³

Crestron Control System Integration

The UC-CX100-T integrates with a Crestron control system to enable touch screen control of room lighting, motorized window shades, climate control, AV, and other amenities.²

Bring Your Own Device (BYOD)

Conference room visitors can connect their laptop to the Crestron Flex system to use their own UC conference platform. The UC Presentation Transmitter (UC-PR) switches to the connected laptop's UC platform and returns to the native platform when disconnected.⁴ For a list of BYOD tested devices on the UC-PR, refer to [OLH Article 1000889](#).

Enterprise-Grade Security

Crestron Flex is an enterprise-grade solution, engineered in partnership with Microsoft to integrate seamlessly into any Microsoft Teams Rooms software deployment. Crestron Flex is ideally equipped for mass deployment throughout any sized corporate, university, medical, military, or government facility.

UC-CX100-T

Crestron Flex Advanced Video Conference System Integrator Kit for Microsoft Teams® Rooms

Easy Provisioning and Device Management

The XiO Cloud service is an IoT cloud-based provisioning service (available separately) that enables installers and IT managers to easily deploy and manage thousands of devices. The XiO Cloud service provides system alerts, network management and provisioning, and the pairing of a control device to the system's UC Engine. System updates are controlled by Windows® software update.

Visit www.crestron.com/xiocloud for additional information.

Premium-Level Support

Crestron Flex Care is an optional subscription service that automatically renews annually, providing 24/7 live remote technical support, an extended five year warranty on Crestron® branded hardware, expedited advance replacements, and a discounted rate for on-site support.

Visit www.crestron.com/flexcare for detailed terms and conditions and additional information.

Dual Control Option

A TS- or TSW- 70 series 10.1 in. touch screen may be added to the solution as an additional control point for the Microsoft Teams Rooms environment.^{2,3}

Deployment Resources

View the [Crestron Flex Pre-Deployment Checklist](#) to help plan your Crestron Flex installation.

Specifications

Included Components

TS-1070-B-S	10.1 in. (257 mm) tabletop touch screen, black
UC-BRKT-260-P-T-ASSY	UC Bracket Assembly comprised of: <ul style="list-style-type: none">• UC Engine: Mini PC with Microsoft Teams video• ADPT-USB-ENET: USB-to-Ethernet Adapter• HD-CONV-USB-260: HDMI® over CAT5 to USB 3.0 converter for content ingest• Mounting hardware
UC-PR	UC Presentation Transmitter with Cable Organizer
CBL-4K-DP-HD-6	DisplayPort™ to HDMI Cable, 6 ft (1.8 m); secondary display

[CBL-CAT5E-7](#)

Ethernet LAN cable for UC Engine, RJ-45-to-RJ-45, black, 7 ft (2.1 m)

[CBL-HD-6](#)

HDMI Interface Cable, 6 ft (1.8 m); primary display

[DM-CBL-ULTRA-PC-20](#)

(2) Ethernet LAN cable, CAT6a, RJ-45-to-RJ-45, blue, 20 ft (6.1 m)

Tabletop Touch Screen

Touch Screen	10.1 in. (257 mm) diagonal capacitive multi-touch TFT active matrix color LCD, 1920 x 1200 pixels
UI	Microsoft Teams UI plus optional Crestron Smart Graphics® room control UI ²
Ethernet	100/1000 Mbps, auto switching, auto negotiating, auto discovery, full/half duplex, TCP/IP, UDP/IP, CIP, DHCP, SSL, TLS, SSH, SFTP (SSH File Transfer Protocol), IEEE 802.1X, SNMP, IPv4 or IPv6, Active Directory® service authentication, HTTPS web browser setup, XiO Cloud® client, IEEE 802.3at compliant
Power over Ethernet	IEEE 802.3at Type 2 compliant PoE+ PD (Powered Device); Normally requests 15 W from an 802.3at Type 2 PSE with LLDP advanced power management; With room scheduling and USB enabled, requests 18 W from an 802.3at Type 2 PSE with LLDP; Requests 30 W (PoE+ Class 4) from an 802.3at Type 2 PSE without LLDP; Requests 15.4 W (PoE Class 0) from an 802.3af (or 802.3at Type 1) PSE
Power	Powered via PoE passthrough on the UC-PR
Construction	Plastic, smooth black finish, edge-to-edge glass with black surround
Dimensions	Height: 5.29 in. (134 mm) Width: 9.63 in. (245 mm) Depth: 4.67 in. (119 mm)
Weight	2.44 lb (1105 g)

UC Bracket Assembly

UC Engine	Mini PC, Intel Core® processor with Windows® 10 IoT Edition OS and 100/1000 Mbps Ethernet connectivity
UC Client	Microsoft Teams Rooms
Management Client	XiO Cloud Service

UC-CX100-T

Crestron Flex Advanced Video Conference System Integrator Kit for Microsoft Teams® Rooms

Content Ingest	HDMI input via CAT5 to USB 3.0 converter
Display Output	Single or dual display support ¹
Display Output Resolution	1080p
Power	UC Engine: 100-240VAC, 50/60 Hz adapter (included); CAT5 to USB 3.0 converter: 24VDC via external 100-240VAC, 50/60 Hz power pack (included)
Construction	Metal mounting bracket, black, preassembled with UC Engine and CAT5 to USB 3.0 content ingest device
Mounting	Surface wall mount behind the display device, or attach to the rear of the display device via the bolts attaching the display to a VESA® compliant display mount; Bracket includes mounting holes on both side edges, spaced 100, 200, and 300 mm vertically, to allow for attachment to either side of the display mounting plate
Dimensions	Height: 15.00 in. (381 mm) Width: 14.50 in. (368 mm) Depth: 1.87 in. (48 mm)
Weight	8.0 lb (3.7 kg)

UC Presentation Transmitter (UC-PR)⁴

Video Input Signal Types	HDMI, DisplayPort™ 1.2 via USB-C® port
Video Output Signal Types	HDMI over CAT5
Resolution	1080p
Video Content Protection	HDCP 1.4 and HDCP 2.2
Audio Input Signal Types	HDMI, DisplayPort 1.2 via USB-C port
Audio Output Signal Types	HDMI over CAT5
Communications	Ethernet: 100 Mbps, auto-switching, auto negotiating, auto-discovery HDMI over CAT5: HDCP, Ethernet HDMI: HDCP USB: USB 2.0 and USB 3.0

Connectors	LAN PoE: (1) 8-pin RJ-45 connector; ACC: (1) USB 3.0 Type B connector; For firmware loading only; USB A: (1) USB 2.0 Type A connector; USB B: (1) USB 2.0 Type B connector; USB: (1) USB 2.0 Type-C connector; HDMI IN: (1) HDMI Type A; To RX: (1) 8-pin RJ-45 connector; Power Jack: (1) DC power connector; LAN: (1) 8-pin RJ-45 connector; Ground: (1) 6-32 screw
Indicators	PWR: (1) Green LED, indicates operating power supplied via power supply Ethernet: (2) LEDs on To RX port; Green indicates Ethernet link status; Amber indicates Ethernet activity
Power Supply	24VDC, 6A, 100-240VAC
Device Charging	Up to 60 W charging for devices connected via USB-C port
Construction	Metal, black finish, integral mounting flanges; Vented top, front, bottom, and sides
Mounting	Surface mount for mounting under table; Attaches to a single rack rail
Dimensions	Height: 1.58 in. (40 mm) Width: 9.25 in. (235 mm) Depth: 8.20 in. (208 mm)

Model

UC-CX100-T

Crestron Flex Advanced Video Conference System Integrator Kit for Microsoft Teams® Rooms

Available Accessories

For a list of available accessories, visit the [UC-CX100-T](#) product page.

UC-CX100-T

Crestron Flex Advanced Video Conference System Integrator Kit for Microsoft Teams® Rooms

Notes:

1. Display must support "Wake on Sync" and "Sleep on No Sync" functionality. Consult the display manufacturer's specifications or internal settings of the specific display.
2. Room control capability (lighting, shades, thermostats, etc.) requires additional equipment and commissioning to be provided by a Crestron authorized integrator and/or programmer. Additional costs may apply.
3. A maximum of two touch screens or one touch screen and one Crestron Mercury device can be accommodated by the system. Only one control device may be connected via direct connection method.
4. The UC-PR uses a USB-C 2.0 connection to provide content sharing, BYOD support, and charging for a user's device. Because USB-C supports multiple functions, device compatibility often varies. While some devices can accept power and data through the same USB-C connection, others cannot. The USB-C port on the UC-PR (labelled "USB") uses DisplayPort alternate mode for transporting video signals. Consult the connected device's user manual or manufacturer to ensure that the device supports DisplayPort alternate mode. Some devices that support DisplayPort alternate mode may not support device charging. For a list of tested devices, refer to [OLH Article 1000889](#). USB-C transfer speeds may vary based on the connected device's processing speed, system configuration, the operating environment, and/or other factors. If the user's device does not support USB-C, then a combination of HDMI and USB B may be used for content sharing or BYOD functionality as described in the [UC-CX100-T Quick Start guide](#) (Doc. 8883).

This product may be purchased from select authorized Crestron dealers and distributors. To find a dealer or distributor, please contact the Crestron sales representative for your area. A list of sales representatives is available online at www.crestron.com/How-To-Buy/Find-a-Representative or contact us for additional information by visiting <https://www.crestron.com/contact/our-locations> for your local contact.

This product is covered under the Crestron standard limited warranty. Refer to www.crestron.com/warranty for full details.

The specific patents that cover Crestron products are listed online at patents.crestron.com.

Certain Crestron products contain open source software. For specific information, please visit www.crestron.com/opensource.

Crestron, the Crestron logo, Smart Graphics, and XiO Cloud are either trademarks or registered trademarks of Crestron Electronics, Inc. in the United States and/or other countries. HDMI is either a trademark or registered trademark of HDMI Licensing LLC in the United States and/or other countries. Intel Core is either a trademark or registered trademark of Intel Corporation in the United States and/or other countries. Active Directory, Microsoft Teams, Skype, and Windows are either trademarks or registered trademarks of Microsoft Corporation in the United States and/or other countries. USB-C is either a trademark or registered trademark of USB Implementers Forum, Inc. in the United States and/or other countries. DisplayPort and VESA are either trademarks or registered trademarks of Video Electronics Standards Association in the United States and/or other countries. Other trademarks, registered trademarks, and trade names may be used in this document to refer to either the entities claiming the marks and names or their products. Crestron disclaims any proprietary interest in the marks and names of others. Crestron is not responsible for errors in typography or photography.

Specifications are subject to change without notice.

©2023 Crestron Electronics, Inc.

Rev 11/16/23

UC-CX100-T

Crestron Flex Advanced Video Conference System Integrator Kit for Microsoft Teams® Rooms

Touch Screen (TS-1070-B-S-T-V)

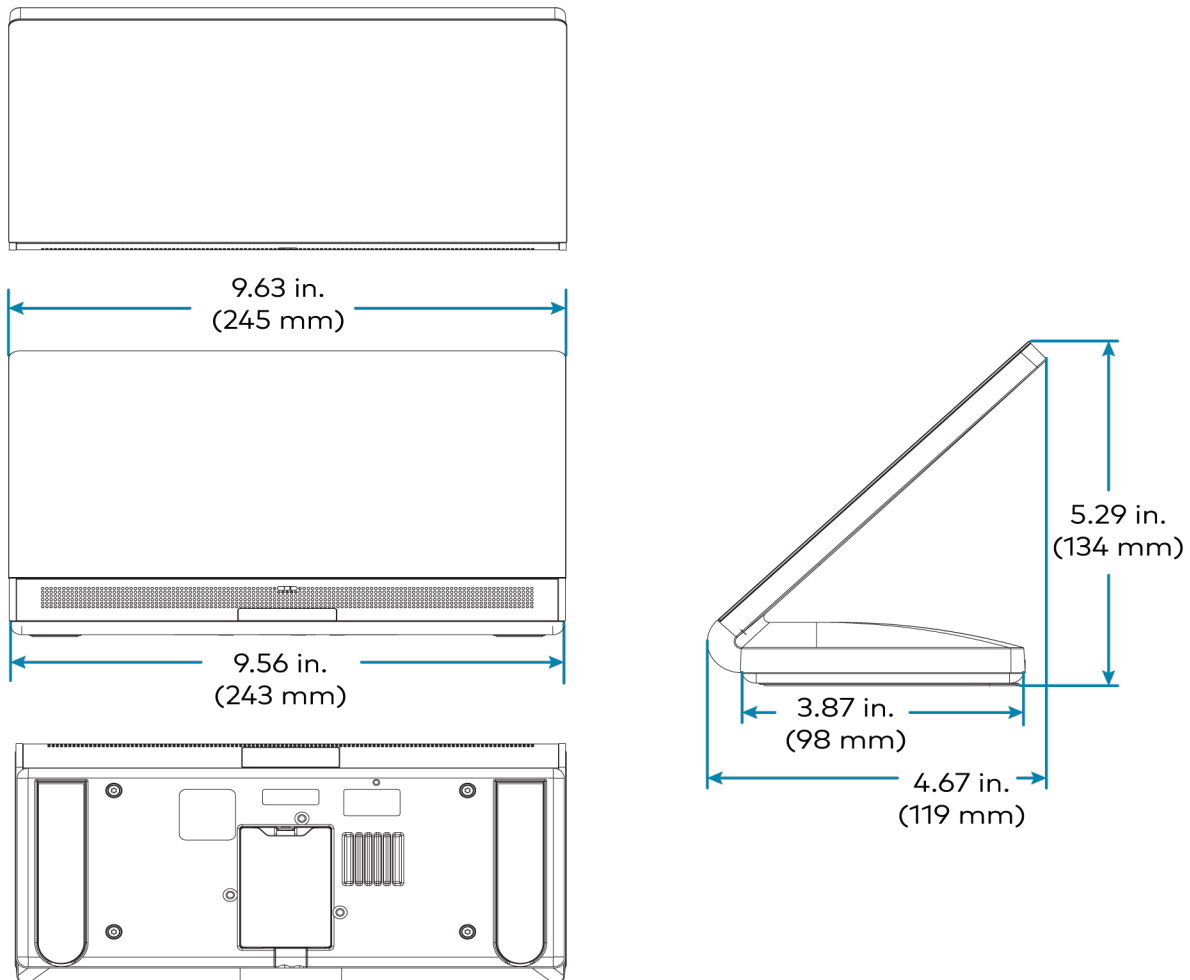

UC-CX100-T

Crestron Flex Advanced Video Conference System Integrator Kit for Microsoft Teams® Rooms

UC Bracket Assembly (UC-BRKT-260-P-T-ASSY)

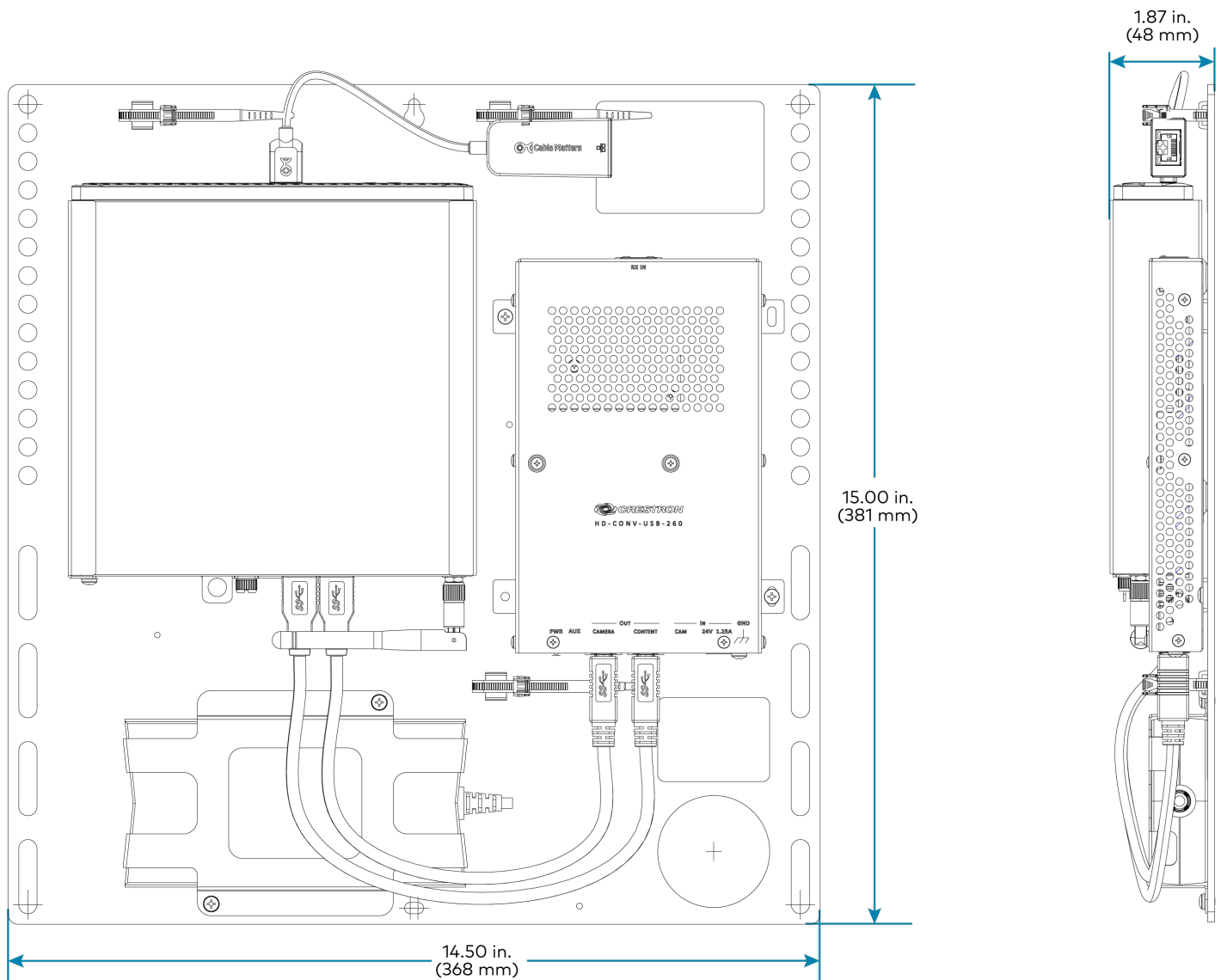

UC-CX100-T

Crestron Flex Advanced Video Conference System Integrator Kit for Microsoft Teams® Rooms

UC Presentation Transmitter (UC-PR)

